

DATASHEET

KSS Radar Level Transmitter

KSS Data Sheet - DS - LM - 004 - 00



Product Overview

The KSS-R800L is the ideal sensor for non-contact level measurement in simple applications. It is particularly suitable for open channel application: exp water/wastewater field, Grease, rain basins, flume, dam level monitoring. Meanwhile the sensors could be applied on some liquid tanks or containers...

- High frequency 80GHz, More Focus.
- Accuracy ± 2 mm (liquid)
- Measuring range up to 20m
- Small emitting angle $\pm 5^\circ$
- Thread connection, customized flange.

With display.

Applications

- Open channel
- Water & wastewater field,
- Grease
- Rain basins
- Flume
- Dam level monitoring.
- River level
- Wet wells
- Inlet screens
- Pump stations
- Water towers
- Chemical

Product Specifications

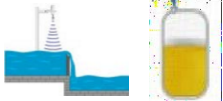
Model	:	KSSR800L
Product Type	:	FMCW Radar Level Transmitter
Application	:	 <ul style="list-style-type: none"> *Open channel water measurement *Standard liquid measurement *Grease
Frequency	:	77GHz-81GHz
Measuring Range	:	Liquid: 0.2m-20m
Accuracy	:	±2mm for liquid
Beam Angle	:	±5°
Material	:	ABS+PP
Process Connection	:	Thread and flange (customized)
Process Temperature	:	-20°C to 60°C (-20 to +140°F)
Process Pressure	:	Normal atmospheric pressure
Signal output	:	4-20mA / RS485/ Bluetooth/Hart
Power	:	Two-wire DC 24V (22V~30V)
Protection	:	IP67
Size	:	85.5mm*130mm, weight 750g



Dimension

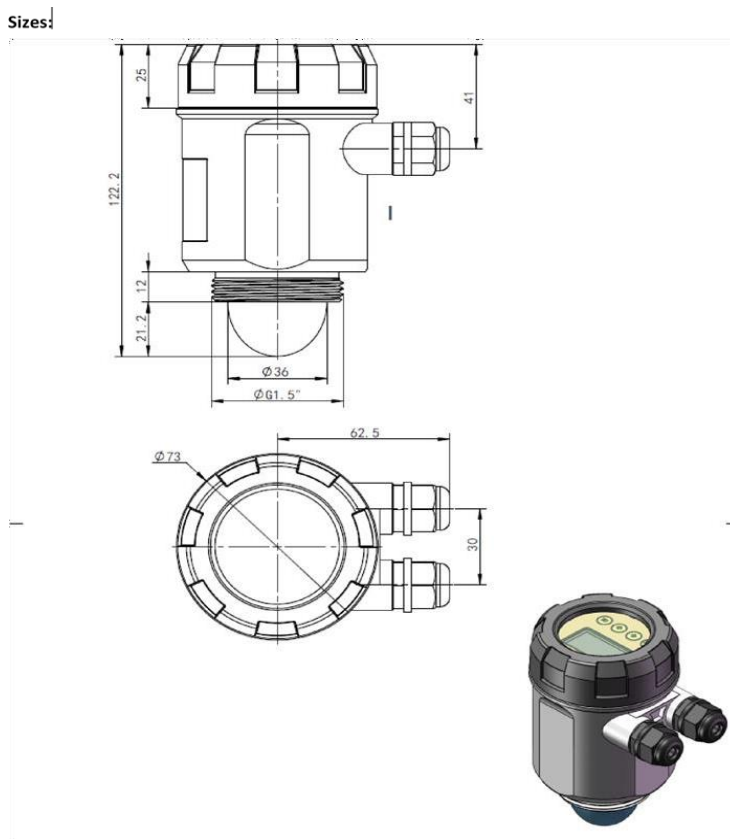

Mobile App

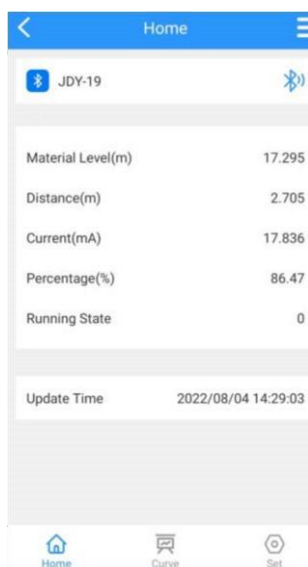

KSS-R800L Model Selection

KSS-R800L

80GHz Radar Level Transmitter (PP housing, no display)

Code	Medium Type
W	Water/liquid
Code	Measuring Range(m)
0.2~15	8、 15
Code	Connection
G	G Thread
F	Flange
Code	Temperature
N	-20 - 60°C
Code	Cable entry
M	M20×1.5(F)
Code	Electronics
T	Two-wire 4...20mA
M	Modbus
B	Bluetooth wireless

KSS-R800L

For inquiries contact us at:

Khot System And Solution

Corporate Office:

Plot no.- Plot No.-75-A/3/5, General Block, MIDC, Telco-Bhosari Road, Behind Union Bank of India, Bhosari, Pune-4110026 India.

Factory Address:

PAP- D-46, Talegaon Industrial Area Phase 2, Mawal, Mendhewadi, Pune-410507 India.



Web.: www.khotsystems.in | **E-mail:** info@khotsystems.in

